

Your ref: DA2022/0107
Our ref: 12547851

18 March 2022

Andy Edwards
Richmond Valley Council
Locked Bag 10
Casino NSW 2470

DA2022/0107 Bentley Quarry, Lot 2 DP1196757, 1465 Bentley Road Bentley – Request for information response

Dear Andy

In response to the letter from Planit Consulting dated 11 March 2022 requesting further information in regards to the above development application, we provide the following:

1. Integrated development authorities

WaterNSW have requested further details on how the proposal is exempt from an Approval or Licence under the Water Management Act. Clause 7 of Schedule 4 of the *Water Management (General) Regulation 2018* exempts certain aquifer interference activities from the requirement of a water access licence, including authorised quarrying activities. This exemption allows up to 3 ML of water to be taken per year without a licence.

As outlined by WaterNSW, this exemption only applies to an aquifer interference activity that is not for the purpose of consumption. Based on advice from WaterNSW in the document *FAQs – Water access licence exemption aquifer interference activities taking 3ML or less of groundwater per year* (WaterNSWFAQ) (see attached), the water is not considered to be used for consumption.

The Water Impact Assessment (GHD 2021) estimated groundwater inflows into the quarry would be 0.6 m³/day or 0.23 ML/year which is less than the 3ML threshold and are expected to evaporate from the pit walls before reaching the in-pit basin. The water take would be incidental to the primary purpose of the activity. If water does reach the basin, it would only be used for dust control, which the WaterNSW FAQ document indicates is possible, while still being exempt.

In our opinion the proposal is exempt, in accordance with Clause 7 of Schedule 4 of the *Water Management (General) Regulation 2018* because:

- The Water Impact Assessment (GHD 2021) indicates the take would be less than 3ML
- If approved, the development would be a lawful quarrying activity
- The water take would be incidental to the main purpose of the activity and is not considered to be consumption, according to the WaterNSW FAQ document.

2. Extraction limit versus transport limit

The proposed maximum extraction, sales and transport volumes per annum from the site would be 300,000 tonnes. The maximum sales and transport volumes per day would be 2,000 tonnes. It is not possible to provide a maximum daily extraction rate because it will depend on the demand and the details of the blast. It could be possible to “extract” 30,000 tonnes or more with each blast.

To confirm, if the quarry operated at its maximum daily volume it would only operate for 150 days.

3. Site preparation

The topsoil from Stage 1 would be stripped and used (along with ENM and VENM) to construct the bunds to the east and west of Stage 1, as indicated on the Proposed Quarry Plan. Prior to Stage 2 commencing, the topsoil will be stripped and used (along with ENM and VENM) to construct the remainder of the bund to the east and west, and the bund to the south.

Overburden is expected to be minimal, if any. It is expected that most, if not all, material extracted will be sold. If some overburden is not suitable for sale, it would be stockpiled in the nominated stockpile area to the east of the extraction area, indicated on the Proposed Quarry Plan.

4. Raw material processing

With the crushing and screening plant, it is difficult to provide the processing capacity because it depends on the type of product being produced. Please find below estimates for two typical types of products produced by using a jaw crusher and screen:

- 200/300 tonnes per hour for 40mm road base
- 100/200 tonnes per hour for 20mm road base

Both the screen and crusher are diesel powered.

In relation to the pre-coat plant, the attached flyer provides some details. In response to the information requested about the pre-coat operations:

- The pre-coat operations would be in the pit.
- The raw materials would be aggregates produced by the quarry and bitumen emulsion stored/provided by the pre-coat plant.
- Volumes are difficult to predict, as indicated by the flyer, the plant can process up to 100 tonnes per hour but the operations are not expected to produce large volumes of pre-coated materials. Based on the typical use estimate in the EIS of 20%, the volume of pre-coated material would be a maximum of 60,000 tonnes per annum.
- Generally the pre-coated material will be made to order, so there would be limited stockpiling of material. Any stockpiles would be covered to prevent leachate runoff.
- The location of the pre-coat operations and stockpiles are difficult to determine because it will depend on when they are required. When required, they would be located near the screen, so there would be minimal handling/transport of the aggregate required.

5. Sensitive receivers

The relevant assessments are currently being updated and will be provided to Council as soon as possible.

6. Pit floor levels

The final RL for the in-pit sump/basin is RL47m which is 2m below the floor of the quarry.

7. Heavy vehicle traffic

If trucks are only operating between 7:00 am and 4:00 pm (i.e., 9 hours) rather than the 10 hours assumed in the Traffic Impact Assessment, when the quarry is operating at 2,000 tonnes and 70 trucks per day this would be about 8 trucks per hour or 1 truck every 7.5 minutes. This is about as fast as a truck can be loaded and weighed, so the limitations of the operation will, by default, ensure an even distribution of trucks throughout the day.

At other times, the distribution of trucks may not be as even but ultimately the limitations of the operation will limit the number of trucks entering and exiting the quarry.

R&S Contracting currently own and operate one truck and dog and one body truck but if the proposal is approved and depending on demand, R&S Contracting may purchase additional trucks. It is anticipated that contractors will also transport material from the site on behalf of clients.

The R&S Contracting trucks are currently parked at the farm shed on the property. It is proposed that the R&S Contracting trucks would continue to be parked at the shed or in the pit, should the quarry be approved.

8. Lighting

We confirm the quarry would only operate during daylight hours, as would most clients, so there is no need for lighting. As outlined by Planit, in winter, the quarry would not operate after about 5:00 pm.

9. Amenities

While an onsite wastewater system is not considered warranted, when there is an adequate system on the property, if Council require it, an Onsite Wastewater System Assessment can be provided, once it is known if Council will support the development application. This is to avoid unnecessary costs for R&S Contracting, until there is more certainty the application will proceed.

10. Government agency consultation

Due to the comprehensive submissions from the relevant agencies included in the Secretary's Environmental Assessment Requirements and the relatively straight forward nature of the proposal, limited consultation with relevant government agencies was considered necessary. Several attempts were made to contact Transport for NSW to understand if they had any concerns given the proximity of the site to Bentley Road but a response was never received.

11. Public submissions

We are currently reviewing the submissions received from the public and will provide a detailed submissions report as soon as possible.

If you have any questions, regarding the above, please contact the undersigned.

Regards



Ben Luffman
Senior Environmental Consultant

+61 2 66505613
ben.luffman@ghd.com

Attachments: WaterNSW FAQ document
Pre-coat plant flyer

Water access licence exemption aquifer interference activities taking 3ML or less of groundwater per year

What activities does the exemption apply to?

The exemption only applies to aquifer interference activities where the water is not being taken for the purpose of its consumptive use or supply. For example, the exemption applies to water taken to ensure safe and efficient excavation when constructing buildings and does not apply to water taken for irrigation or town water supply.

How do I know if my activity is aquifer interference?

Works or activities that intersect or interfere with groundwater systems and where take is incidental to the primary purpose of the activity, or where there is no take, are managed as aquifer interference activities. Works or activities that are for the purpose of supplying water for consumptive use are managed as water supply activities.

Why is the exemption set at 3ML per year?

3ML per year is similar to the volume of water taken by landholders in accordance with domestic and stock rights held under section 52 of the *Water Management Act 2000*, for which a water access licence is not required to be held.

What if I take more than 3ML?

A water access licence and appropriate entitlement are required if your aquifer interference activity takes more than 3ML of groundwater in a water year. Refer to this [fact sheet](#) for more information.

Can I use the water I take?

Yes. Groundwater taken incidentally may subsequently be used for consumption or supply (for example for dust suppression, washing equipment or mixing concrete).

What about the cumulative impacts of water taken under this exemption?

The risks from potential cumulative impacts of this exemption are low as many of these activities are temporary and take only small volumes of groundwater. The exemption also formalises longstanding licensing practise so is unlikely to generate an increase in take from groundwater systems. A major benefit of the exemption for water management is that proponents must report the volume of groundwater taken.

My activity is complying development – can I claim the licence exemption?

Yes. Complying development is an authorised activity under the *Environmental Planning and Assessment Act 1979*.

Water access licence exemption aquifer interference activities taking 3ML or less of groundwater per year

Is the first 3 ML of groundwater taken by mining or coal seam gas production exempt from needing a licence?

No. The exemption only applies for these activities at the exploration stage. A water access licence and appropriate entitlement are needed for any groundwater taken at the production stage of mining and petroleum activities.

Do the metering regulations apply?

No. A meter is not required to measure water take, but the method used to measure the water taken must be reported.

How do I report my take?

For the 2019/20 water year, the [groundwater take under exemption form](#) which can be downloaded from the WaterNSW website. For the 2020/21 year the intention is to be able to make and submit their records electronically.

Why do I have to report water taken under this exemption?

Records of water taken under a licence exemption provide a greater understanding of the full volume of water being taken from a groundwater source under licences, basic landholder rights and exemptions each year. This will inform decision making and enable better management of the groundwater source.

I am only taking a few hundred litres of water – do I still need to record and report the water taken under the exemption?

Yes, although consideration is being given to a volumetric take threshold for the 2020/21 water year below which recording and reporting will not be required. Recording of all water take is required in the intervening period.

Can I report my take under several exploration titles that are part of one project on one form?

Yes, but it must clearly be indicated which title (authorised project) the take belongs to.

Can I still report my take after 29 July for the 2019/20 water year?

Yes. Although the form for making this record was not available before 29 July 2020, the current reporting form should be used to report any take made under the exemption during the 2019/20 water year.

More information

[See fact sheet](#) for this exemption.

If you have any questions, please contact one of our friendly Customer Service team on [1300 662 077](tel:1300662077) or email Customer.Helpdesk@waternsw.com.au



Precoat plant being configured for transport

- » Pre-coating capacity of 100T/hr and emulsion



Plant producing pre-coated aggregate

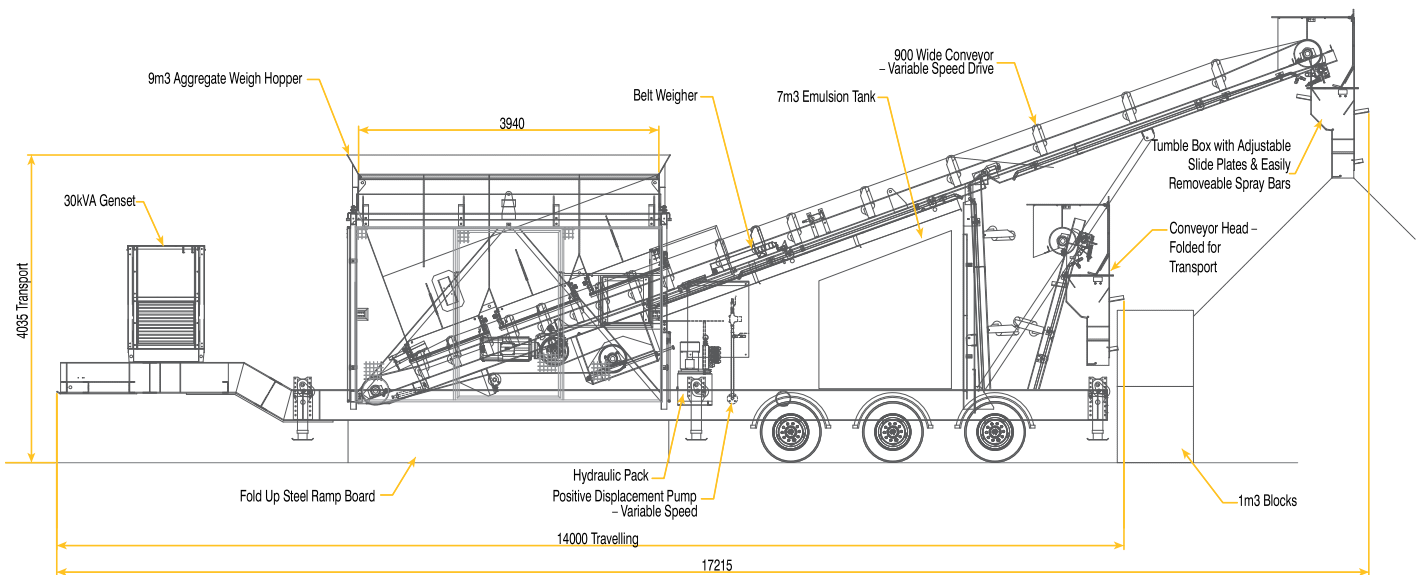

Computer controlled mobile pre-coat plant with emulsion storage tank.

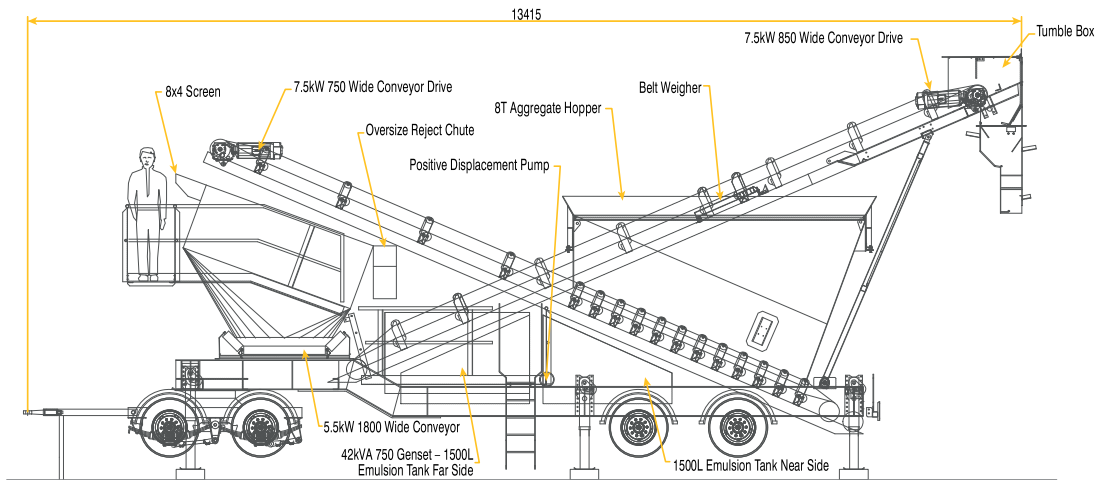

Mobile pre-coat plant with screen deck. The 8' x 4' two deck vibrating screen is mounted on the front goose-neck of the chassis with an oversized chute discharging product outside of the chassis.

Mobile pre-coat plant